

STAKKAbox™ Modula

Access Chamber Section

450mm x 450mm



Product Description

STAKKAbox™ Modula is a range of modular access chambers, made from 150mm deep riser sections which stack and interlock to offer flexibility in finished chamber depths.

Product Details

Clear Opening:	450mm x 450mm	Weight:	4.9kg
External Dimensions:	543mm x 543mm	Product Code:	CPMORS-04500450
Stacking Depth:	155mm	Delivery Options:	Solid Ring
Actual Depth:	165mm		



Materials Properties

Material Profile	Polypropylene (PP)	Black
Tensile Strength	ISO 527-4	27.6 MPA
Flexural Strength	ISO 14125	40 MPA
Flexural Modulus	ISO 14125	2.4 GPA
Impact Strength	ISO 179	50 J/mm ²
Deflection Temperature Range (0.46MPA)	ISO 75-2	82.2°C
Density (g/cm ³)	ISO 1183	1.05 g/cm ³
Water Absorption	ISO 62	0.03%
Volume Resistivity	IEC 60093	1.00E +16
Fire Performance	UL 94	HB
Limited Oxygen Index	ISO 4589-2	21%

Installation

STAKKAbox™ Modula has been tested to withstand vertical loads of EN124. Please refer to the STAKKAbox™ Installation Guide for installation details.

Key Features

- Fast and easy to install
- Sectional & twin wall design
- Smooth outer walls with lip to 'key' in



Scan for access to technical documents library



Modula cross-section detail

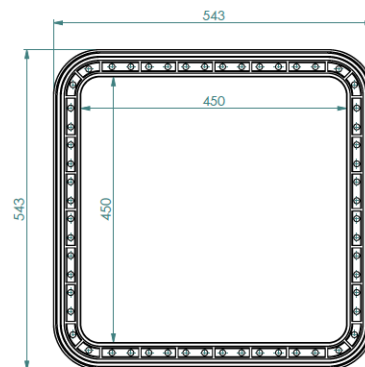

Modula cross-section top view

CPMO-04500450 V.01 18/12/2018